

# Stainless System Pipe System

Installation Manual

2022 V1.0

## Table of content

Operating Conditions, Installations in explosive environments, Purity Remark & Safety Instructions	3
Product Information	5
LMRA (Last Minute Risk Assessment)	6
Commissioning report	8
Cleaning products	10
Expansion Loops and Compensators	11
Pipe Support	13
<b>Tools</b>	<b>14</b>
Overview	14
Inspection and maintenance	15
<b>Installation</b>	<b>16</b>
Pipe Preparation	16
Diameters 15 -35 mm / 1/2" - 1 1/4"	18
Diameters 42 - 54 mm / 1 1/2" - 2"	19
Diameters 76 - 108 mm / 2 3/4" - 4"	20
Minimum distances and space requirements for pressing	21

# Operating Conditions

## Operating Conditions

PiPress™ stainless steel pipes and fittings are designed to convey compressed air and vacuum. The system can also be used for nitrogen, helium, argon, neon, xenon and krypton.

PiPress™ system can only be used to convey compressed air, Vacuum & inert gases and the allowed medium can be in direct contact with the final product or process. However, PiPress™ system cannot be used for conveying the finished products, for example, chemicals, food products, cement etc.

PiPress™ stainless steel pipes and fittings must only be used within the pressure and temperature specifications referred to in the PiPress™ Stainless Product Information Sheet.



PiPress™ stainless steel pipes and fittings must be appropriately protected against violent impacts and wind gusts.

Ensure accessibility of the PiPress™ system for possible future system expansion or maintenance.



PiPress™ stainless steel pipes and fittings should not be used as support for electrical equipment or earth conductors.



PiPress™ stainless steel pipes should never be directly connected to a source of vibrations (use hoses instead).

Pressure relief valves must be installed where needed to ensure that the system working pressure cannot exceed the maximum working pressure of PiPress™ Stainless Steel.



PiPress™ pipes and fittings are not suitable for direct contact with soil. A watertight

PVC pipe suited for underground or outside installations can be used to install around the PiPress™ pipe.

## PiPress™ installations in explosive environments

Cutting, deburring and assembly of PiPress™ stainless steel pipes can create sparks. Necessary precautions in explosive atmospheres must be taken.



PiPress™ stainless steel installations in explosive environments must always be earthed. Bonding and earthing must be checked at frequent intervals to secure that the system cannot be electrically charged.

## Purity Remarks

To guarantee the purity of the compressed air at the point of use:

- a system purge of at least 24h is highly recommended.
- a properly sized certified point-of-use filter is advised, depending on the application requirements.

PiPress™ stainless steel cannot be allowed to convey any end products (food, beverage, pharmaceuticals, etc.)

# Safety Instructions

## Safety Instructions



PiPress™ is not meant to bear weight beside its own weight. Heavier accessories incorporated into the PiPress™ system (like filters or valves) need proper supporting.



Do not use any other brand fittings or pipes in combination with PiPress™ products.

Installation, adjustments and repair work of an PiPress™ system must be performed by authorized trained personnel.



Installers must use the necessary protection means (PPMs). When working at heights, use a harness for personal protection, and ensure that tools are securely fastened to prevent them from falling.

Installers must comply to all local safety requirements related to the application(s) in scope. Special care must always be taken to prevent suffocation risks when working with gases other than air.



Please consider the potential galvanic corrosion when combining parts with different material.

Before any installation, adjustment, repair work or other non-routine checks, relieve the PiPress™ system of pressure and effectively isolate the system from all sources of pressure.



Only genuine PiPress™ parts should be used when installing, adjusting or repairing an PiPress™ stainless steel system.

All plugs and caps must be removed before installing the PiPress™ pipes.



Check the surface of the PiPress™ pipes before installing. There should be no relevant scratches, abrasions, dents etc.



Use only solvents or chemicals which do not damage the materials of PiPress™.

Please conduct an LMRA (last minute risk assessment) before commencing an PiPress™ installation.



Before using the PiPress™ stainless steel system, installers must ensure that all necessary test controls and applicable rules for the specific installation are complied with.

At initial startup of the PiPress™ system, apply a test pressure of 1.5 bar to identify leakage or imperfect joints. After performing an inspection, increase the pressure gradually and constantly (max 1 bar every 5 minutes) and perform a second inspection for leakages or imperfect joints at the final pressure.

Never use damaged PiPress™ fittings or tools.

PiPress™  
stainless steel  
**Product  
Information**

PiPress™ stainless steel is a piping system designed to deliver a fast, easy, reliable and clean distribution network for water, industrial water, heating & cooling, compressed air, nitrogen, vacuum specifically for industries that demand the highest quality of air.

<b>Product Range</b>	Pipes SS304/SS316L: DN15 (½"), DN22(¾"), DN28 (1"), DN35 (1 ¼"), DN42 (1 ½"), DN54 (2"), DN76( 2¾"), DN89(3½"), DN108(4")	
<b>Applications</b>	Water, Industrial water, heating & cooling, Compressed Air, Nitrogen, Gas, Vacuum...	
<b>Material</b>	Stainless Steel AISI 316L 1.4404 Stainless Steel AISI 304L 1.4301	EN10088 ASTMA666
<b>Safety factor</b>	4, Burst pressure > 64 Bar (> 928 PSI)	
<b>Max Working pressure</b>	16 Bar (232 PSI)	
<b>Working temperature</b>	-20°C to 120°C (- 4°F to 248° F)	
<b>Vacuum level</b>	20 mbar (0.29 PSI) abs	
<b>Dewpoint</b>	Lowest allowable pressure dewpoint is -70°C (-94°F)	
<b>Treatment</b>	Annealing	

<b>Fittings</b>	D15 (½"), D28 (1"), D35 (1 ¼"), D42 (1 ½"), D54 (2"), D76 (2 ¾"), D89 (3 ½"), D108 (4")		
<b>Connection</b>	Press fit system		
<b>Materials</b>	SS304, SS316L	EN10088 ASTMA666	
<b>Seal fittings</b>	EPDM, NBR, FKM (fluoroelastomer)		

# LMRA (Last Minute Risk Assessment)

This checklist is a risk assessment to be performed on-site at the customer and must be preceded by a detailed risk assessment.

**General**

**STEP 1: EVALUATION BEFORE THE START OF WORK**

	YES	NO	N/A
Do I know what to do and how?			
Am I trained to do this kind of work?			
Is my work equipment suitable and in good condition / inspected?			
Do I have the necessary PPE, and do they offer appropriate protection?			
Do I have a work permit that allows me to start?			
Is my working environment free of slipping, tripping and/or falling hazards?			
Is my work environment sufficiently enlightened?			
Have I identified all energy sources and followed the Lock Out – Tag Out procedure?			
Do I know the VGM regulations of dangerous products that I am going to use?			
Is the atmosphere in and around my work environment safe? (confined space, explosion)			
Is the danger of falling objects excluded?			
Am I sufficiently protected against falls from height?			
Are the weather conditions good?			
Can I lift loads manually in an ergonomic way?			
Is my work environment defined?			
Is there regular supervision when I work in isolation?			
Am I aware of the risks of other activities in my work environment?			
Do I know the locations of first aid equipment (e.g. emergency shower, eyewash bottle)			
Do I know the locations of firefighting equipment (e.g.; extinguisher, reel)			
Do I know the alarm procedure and numbers in the event of a fire or accident?			
Do I know my escape route and evacuation site?			
Have I taken all measures to prevent environmental pollution?			

# LMRA (Last Minute Risk Assessment)



	YES	NO	N/A
Did I read and understand the installation manual for PiPress™ - www.piprotech.com			
Is scaffolding and/or lifting equipment inspected and in good condition?			
Will the PiPress™ system be installed within the limits of the product in terms of environment, pressure and temperature?			
Will the PiPress™ system be used for the gasses mentioned in the technical datasheet OR has a written confirmation from the manufacturer been obtained that claims PiPress™ can be used for this type of gas?			
Will the PiPress™ system be properly earthed (electrically)?			
Did I check for any damage to the PiPress™ material due to transport?			

## STEP2: MEASURES TO ELIMINATE OR REDUCE EXISTING RISK TO AN ACCEPTABLE LEVEL

## STEP3: PRESENT WHEN FOR MATING THIS LMRA

Name	Date	Signature

# Commissioning report

Certified installer:	Responsible PiPress™ champion:
Customer:	Commissioning date (dd/mm/yyyy):
Customer address:	
<input type="checkbox"/> Expansion of existing installation	<input type="checkbox"/> New installation

## Before installation

### SAFETY

- All safety instructions at customer site have been acknowledged and applied.
- The PiPress™ installation manual (latest version is available on the website: <https://www.piprotech.com/en>) has been read and understood. The installation is carried out in accordance with the instructions in this manual.

### MEDIUM

- Compressed air
- Vacuum
- Nitrogen
- Other: \_\_\_\_\_

	T <sub>MAX</sub> _____ °C / °F
	T <sub>AVG</sub> _____ °C / °F
	T <sub>MIN</sub> _____ °C / °F
	Working pressure _____ bar(g) / psi

### AMBIENT CONDITIONS

The installation is installed:

- Indoor
- Outdoor
- The piping is protected against violent impacts and wind gusts

### NETWORK LAYOUT

- To ensure proper draining of condensate, pipes should be sloped at 1-2% and a drain point should be foreseen at every lowest point of the line.
- Ensure that pressure vessels are bolted to the floor, and that vibrations may not be transmitted to the PiPress™ piping.
- Expansion loops  
Number of expansion loops or compensators: \_\_\_\_\_

Longest straight line: \_\_\_\_\_ m/ft

## Installation

- Check if enough supporting is used based on the table on the right. The table shows the maximum allowed distance L between two pipe clips.

External pipe diameter (mm / inch)	Maximum distance (m / ft)
15 / ½"	1,5 / 5
28 / 1"	2,5 /
35 / 1 ¼"	8 2,5 /
42 / 1 ½"	3 / 10
54 / 2"	3,5 / 11,5
76 / 2 ¾"	4 / 13
89 / 3 ½"	4,5 / 14,5
108 / 4"	5 / 16

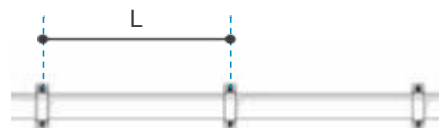

# Commissioning report

All valves and flanges are supported by a pipe clip on both sides

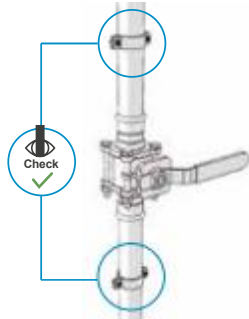

Insertion depth markers have been checked on at least 10% of fittings

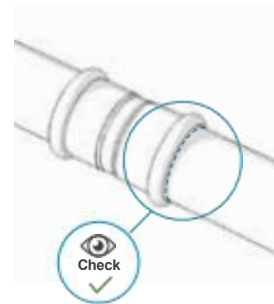

## Commissioning

The installation has been tested according to the procedure below

1. Apply pressure of 1,5 bar / 22 psi to the system.
2. Check if the pressure is dropping between the end of the line and the vessel. If pressure remains stable, go to point 4.
3. Use leak finder spray or an ultrasonic leak detector to find the leak. Depressurize the system, rectify the leak and go back to step 1.
4. Increase pressure gradually (max 1 bar / 14 psi every 5 minutes)
5. Close the main valve and monitor the pressure at the end of the line for 30 minutes.  
If the pressure is dropping, go to point 3.
6. To be checked: 24h before handover

Leaks / disconnections detected during first pressurization at 1,5 bar / 22 psi

- No
- Yes, \_\_\_\_\_ leaks found
- Yes, \_\_\_\_\_ disconnections

Leaks / disconnections detected during final pressurization at working pressure

- No
- Yes, \_\_\_\_\_ leaks found
- Yes, \_\_\_\_\_ disconnections

What is the pressure difference between the compressor room and final point of use? \_\_\_\_\_ bar(g)

## Signatures

PiPress™ installer	PiPress™ champion	Customer representative

# Cleaning products

Product	Usage in the field	Aluminum of pipes	Bluecoating on alu pipes	PFseries fittings	Brass couplings	NRBRubber seals of butterfly valves	Blackcoating on PM series	Stainless steel 304L	Stainless steel 316L	O-rings in SS fittings
<b>Disinfection/sterilization</b>										
Ethyl Alcohol (ethanol) (60-90%)	Seldom, used on small external surfaces	Good	Good	Good	Good	Good	Resistant	Good	Good	Good
Isopropyl alcohol (isopropanol)	Seldom, used on small external surfaces	Good	Good	Good	Good	Good	Resistant	Good	Good	Good
Amphoterics		Good	Unknown	Unknown	Unknown	Unknown	Unknown	Good	Good	Unknown
Quaternary ammonium compounds (QAC)	environmental sanitation of noncritical surfaces	Good	Unknown	Unknown	Good	Unknown	Unknown	Good	Good	Unknown
Gluteraldehyde	high-level disinfectant for medical equipment, not for non-critical surfaces	Good	Unknown	Good (Butanal: partially resistant)	Good	Good	Unknown	Good	Good	Unknown
Formaldehyde	Seldom, produces carcinogenic fumes	Good	Unknown	Good (at concentration of 40% or less)	Good (at concentration of 40% or less)	Good (at concentration of 40% or less)	Good	Good	Good	Good (at concentration of 40% or less)
<b>WholeRoom disinfection/sterilization</b>										
QACfogging		Unknown	Unknown	Unknown	Unknown	Unknown	Good	Unknown	Unknown	Unknown
<b>Cleaning (components)</b>										
surfactants (detergents in general)		Good	Unknown	Good	Good	Good	Good	Good	Good	Good
Ethylene diamine tetracetic acid (EDTA)		Unknown	Unknown	Good	Not resistant	Good	Unknown	Good	Good	Not resistant

# Expansion loops and compensators

Long straight pipes will expand or contract due to temperature variations. To compensate for this effect, expansion loops or compensators are required. An expansion loop is a U-shaped construction that compensates the variation in length. Compensators are straight fittings specifically designed to allow axial movement. The number of expansion loops / compensators depends on the total length of the straight line and the maximum temperature variation.

The below table gives the maximum possible straight distance between two expansion loops with fixed piping vs. the temperature variation:

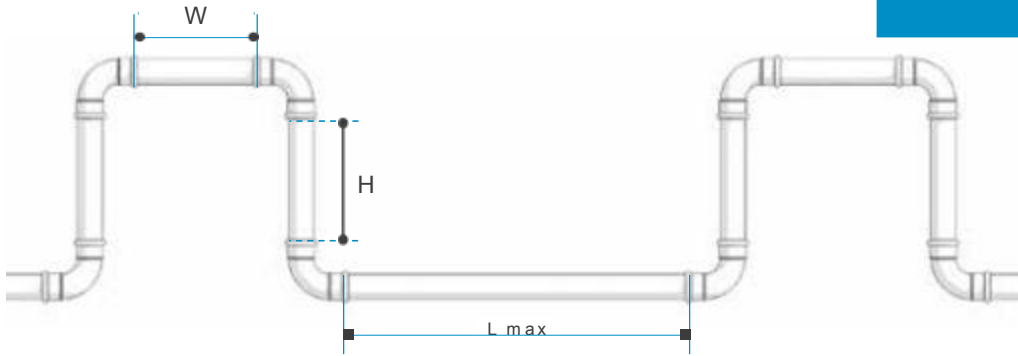

	Ø15 mm / 1/2"	Ø28 mm / 1"	Ø35 mm / 1 1/4"	Ø42 mm / 1 1/2"	Ø54 mm / 2"	Ø76 mm / 2 3/4"	Ø89 mm / 3 1/2"	Ø108 mm / 4"
<b>H</b>	0,75 m / 2,5 ft	1 m / 3,3 ft		1,25m / 4,1 ft		1,5 m / 5 ft		1,75 m / 5,75 ft
<b>W</b>	0,375 m / 1,25 ft	0,5 m / 1,6 ft		0,625m / 2 ft		0,75 m / 2,5 ft		0,875 m / 2,9 ft
<b>Δt</b>	Maximum distance between two expansion joints							
5°C / 9°F	726 m / 2383 ft	691 m / 2269 ft	553 m / 1815 ft	720 m / 2364 ft	560 m / 1838 ft	573 m / 1881 ft	489 m / 1606 ft	549 m / 1802 ft
10°C / 18°F	363 m / 1191 ft	345 m / 1134 ft	276 m / 907 ft	360 m / 1182 ft	280 m / 919 wft	286 m / 940 ft	244 m / 803 ft	274 m / 901 ft
20°C / 36°F	181 m / 595 ft	172 m / 567 ft	138 m / 453 ft	180 m / 591 ft	140 m / 459 ft	143 m / 470 ft	122 m / 401 ft	137 m / 450 ft
30°C / 54°F	121 m / 397 ft	115 m / 378 ft	92 m / 302 ft	120 m / 394 ft	93 m / 306 ft	95 m / 313 ft	81 m / 267 ft	91 m / 300 ft
40°C / 72°F	90 m / 297 ft	86 m / 283 ft	69 m / 226 ft	90 m / 295 ft	70 m / 229 ft	71 m / 235 ft	61 m / 200 ft	68 m / 225 ft
50°C / 90°F	72 m / 238 ft	69 m / 226 ft	55 m / 181 ft	72 m / 236 ft	56 m / 183 ft	57 m / 188 ft	48 m / 160 ft	54 m / 180 ft
60°C / 108°F	60 m / 198 ft	57 m / 189 ft	46 m / 151 ft	60 m / 197 ft	46 m / 153 ft	47 m / 156 ft	40 m / 133 ft	45 m / 150 ft
70°C / 126°F	51 m / 170 ft	49 m / 162 ft	39 m / 129 ft	51 m / 168 ft	40 m / 131 ft	40 m / 134 ft	34 m / 114 ft	39 m / 128 ft
80°C / 144°F	45 m / 148 ft	43 m / 141 ft	34 m / 113 ft	45 m / 147 ft	35 m / 114 ft	35 m / 117 ft	30 m / 100 ft	34 m / 112 ft
90°C / 162°F	40 m / 132 ft	38 m / 126 ft	30 m / 100 ft	40 m / 131 ft	31 m / 102 ft	31 m / 104 ft	27 m / 89 ft	30 m / 100 ft
100°C / 180°F	36 m / 119 ft	34 m / 113 ft	27 m / 90 ft	36 m / 118 ft	28 m / 91 ft	28 m / 94 ft	24 m / 80 ft	27 m / 90 ft

# Expansion loops and compensators



The table below gives the maximum possible straight distance between two compensators vs. the temperature variation:

	Ø15 mm / 1/2"	Ø28 mm / 1"	Ø35 mm / 1 1/4"	Ø42 mm / 1 1/2"	Ø54 mm / 2"
Δt	Maximim distance between two compensators (1000 cycles max.)				
5°C / 9°F	193 m / 636 ft	266 m / 874 ft	315 m / 1033 ft	387 m / 1272 ft	436 m / 1431 ft
10°C / 18°F	96 m / 318 ft	133 m / 437 ft	157 m / 516 ft	193 m / 636 ft	218 m / 715 ft
20°C / 36°F	48 m / 159 ft	66 m / 218 ft	78 m / 258 ft	96 m / 318 ft	109 m / 357 ft
30°C / 54°F	32 m / 106 ft	44 m / 145 ft	52 m / 172 ft	64 m / 212 ft	72 m / 238 ft
40°C / 72°F	24 m / 79 ft	33 m / 109 ft	39 m / 129 ft	48 m / 159 ft	54 m / 178 ft
50°C / 90°F	19 m / 63 ft	26 m / 87 ft	31 m / 103 ft	38 m / 127 ft	43 m / 143 ft
60°C / 108°F	16 m / 53 ft	22 m / 72 ft	26 m / 86 ft	32 m / 106 ft	36 m / 119 ft
70°C / 126°F	13 m / 45 ft	19 m / 62 ft	22 m / 73 ft	27 m / 90 ft	31 m / 102 ft
80°C / 144°F	12 m / 39 ft	16 m / 54 ft	19 m / 64 ft	24 m / 79 ft	27 m / 89 ft
90°C / 162°F	10 m / 35 ft	14 m / 48 ft	17 m / 57 ft	21 m / 70 ft	24 m / 79 ft
100°C / 180°F	9 m / 31 ft	13 m / 43 ft	15 m / 51 ft	19 m / 63 ft	21 m / 71 ft

### Example:

Consider an installation with a 100m / 328 ft straight line in 15mm / 1/2" pipe. The minimum temperature of the system is -20°C / -4°F in the winter, and the maximum temperature is 50°C / 122°F due to hot compressed air when the system is in use. The Δt is then 70°C / 126°F.

For this 100m / 328 ft straight line, this means that 1 expansion loop is required. This means that for this straight line, 7 compensators are required.

## Pipe support

The maximum distance L between two pipe clips is given by the table below:

Make sure the piping system is rigidly supported to the structure of the building so that movement due to external forces (e.g. wind) of the piping is prevented.

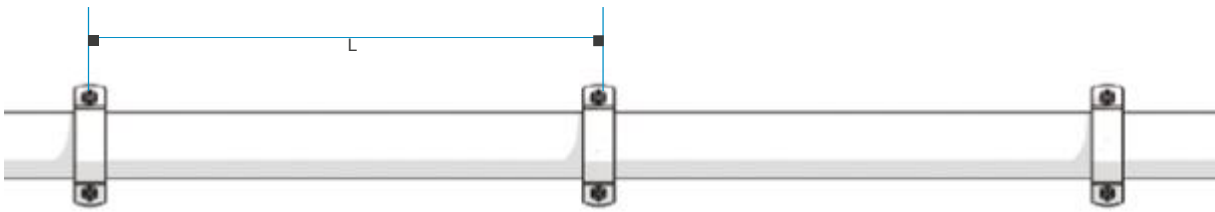

External Pipe Diameter (mm / inch)	Maximum distance (m / ft)
15 / ½"	1,5 / 5
28 / 1"	2,5 / 8
35 / 1 ¼"	2,5 / 8
42 / 1 ½"	3 / 10
54 / 2"	3,5 / 11,5
76 / 2 ¾"	4 / 13
89 / 3 ½"	4,5 / 14,5
108 / 4"	5 / 16

**Valves must be supported by pipe clips on both sides, with a maximum distance of 0.5m (20") between the valve and the pipe clips.**

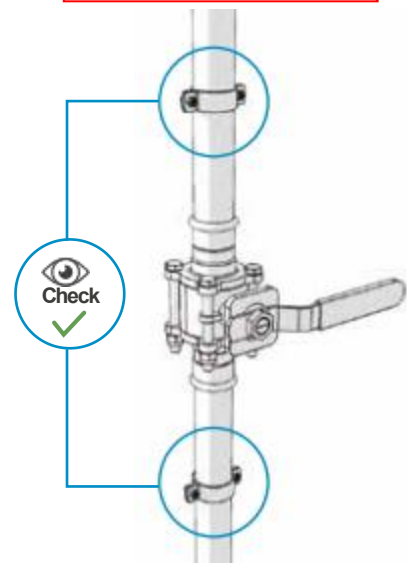

# Tools - Overview

**DN15-DN35**  
1/2" - 1 1/4"



DN15, DN18, DN22, Dn28, DN35

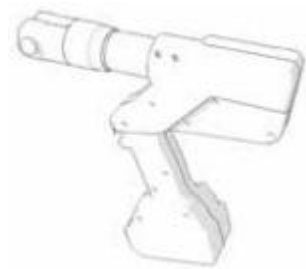

PT1550  
Including protective case,  
battery charger, charger cable

**DN42 - DN54**  
1 1/2" - 2"

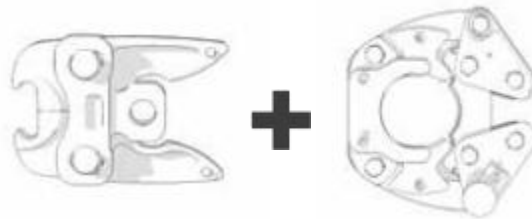

D42 / 1 1/2"  
D54 / 2"

**DN76-DN108**  
2 3/4" - 4"



DN76 / 2 3/4"  
DN89 / 3 1/2"  
DN108 / 4"

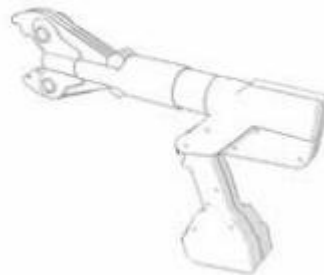

PT65100  
Including protective case,  
battery charger, charger cable,  
cable to work on power grid

Note: the PiPress™ Stainless Steel System will only attain the designed pressure when installed using the tools in the table above. Using other tools is not recommend, as this may lower the pressure rating.

# Tools - Inspection and maintenance

To guarantee correct installation, the pressing tools must be checked regularly by an official authorized repairer according to the manufacturer specifications.

All moving parts and pressing surfaces must be cleaned and lubricated daily.

Before starting installation, make sure to inspect the tools thoroughly. Any possible oxidation, paint or dirt will affect the reliability, possibly resulting in sliding issues on the fittings during pressing.

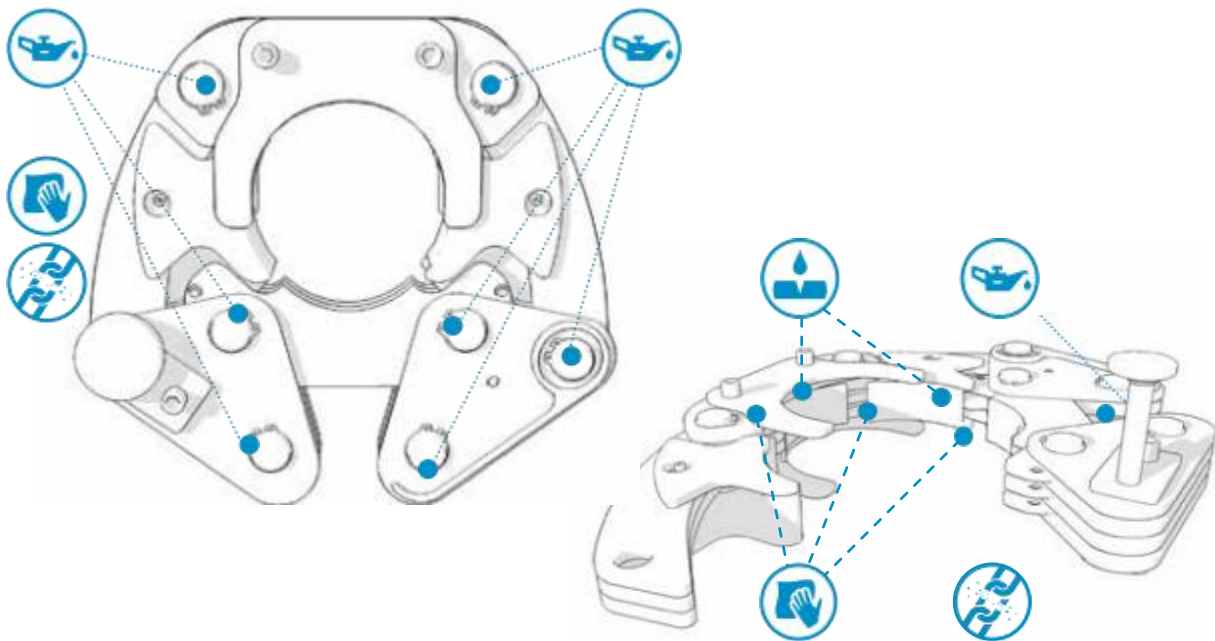

Keep the chain clean



Keep the pins lubricated with oil



Keep the pins lubricated with grease



Attention it can break

# Installation - Pipe preparation

## 1 Measure

Pipe Outside Diameter (mm/inch)	A mm/ inch	D (mm/inch)	L (mm / inch)
15 / ½"	20 / 13/16"	20 / 13/16"	60 / 2 3/8"
28 / 1"	23 / 15/16"	20 / 13/16"	66 / 2 5/8"
35 / 1 ¼"	26 / 1"	20 / 13/16"	72 / 2 13/16"
42 / 1 ½"	30 / 1 3/16"	40 / 19/16"	100 / 5 ½"
54 / 2"	35 / 1 3/8"	40 / 19/16"	110 / 4 5/16"
76 / 2 ¾"	55 / 2 3/16"	60 / 2 3/8"	170 / 6 11/16"
89 / 3 ½"	60 / 2 3/8"	60 / 2 3/8"	180 / 7 1/16"
108 / 4"	75 / 2 15/16"	60 / 2 3/8"	210 / 8 ¼"

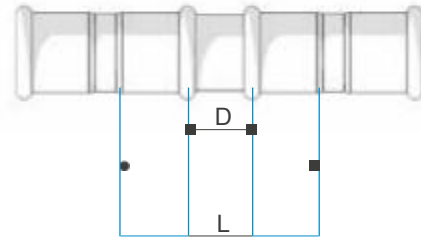
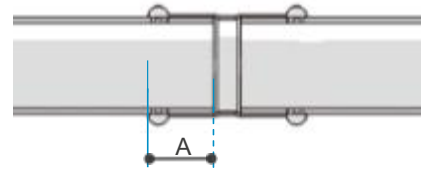

A = Insertion Depth  
 D = Minimum Distance  
 L = Minimum Pipe Length Tube

## 2 Cut

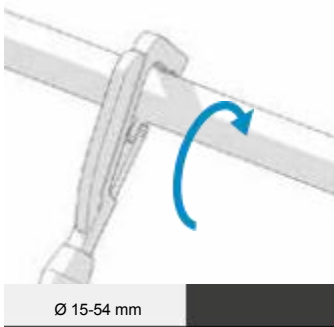

OR



## Installation - Pipe preparation

**3** Check

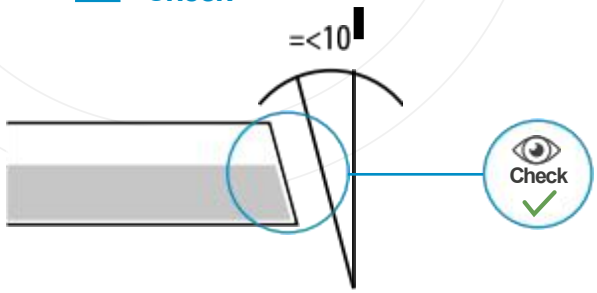

**4** Deburr

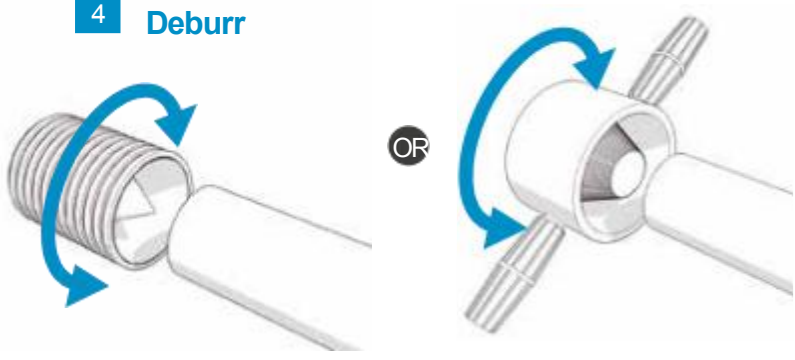

Ø 15-54 mm    2810 0141 00

Ø 76 - 108 mm    2810 0641 00

**5** Mark

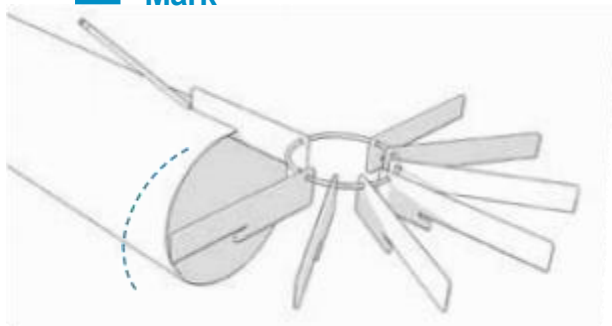

Pipe Marker    2812 0029 80

# Installation Pressfitting

Diameters 15 - 35 mm / 1/2" - 1 1/4"

**0** Check O-ring for damage

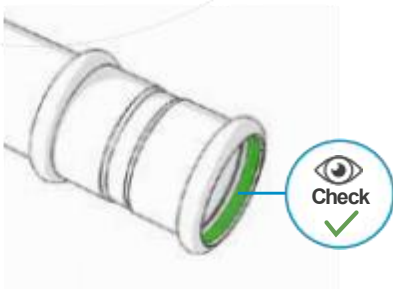

**1** Insert

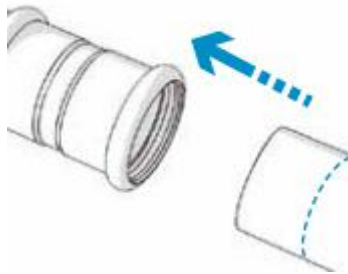

**2** Check

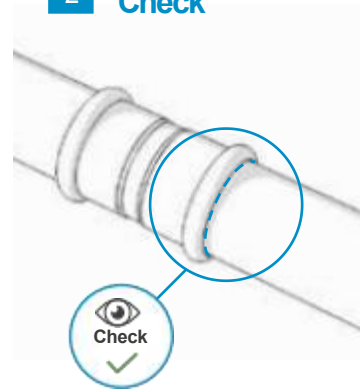

**3** Press

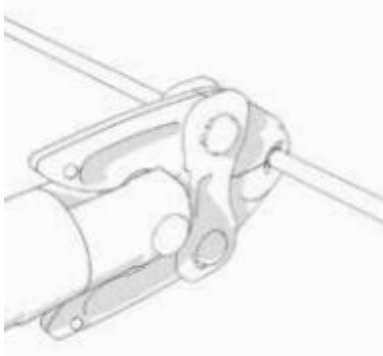

**4** Check

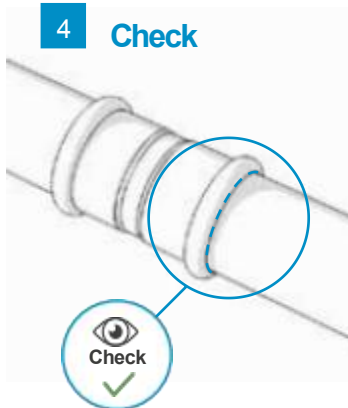

# Installation - Pressfitting

Diameters 42 - 54 mm / 1 1/2" - 2"

**0** Check O-ring for damage

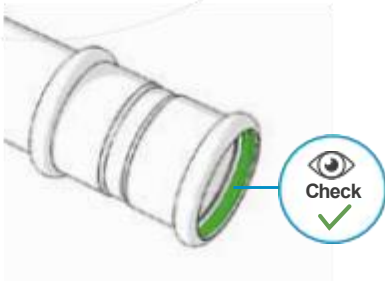

**1** Insert

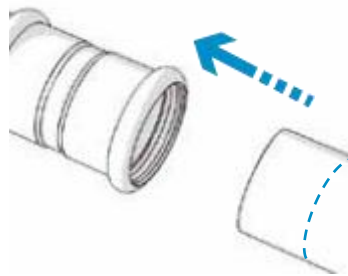

**2** Retract pin and open chain

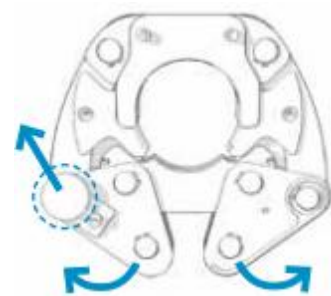

**3** Close chain and insert pin

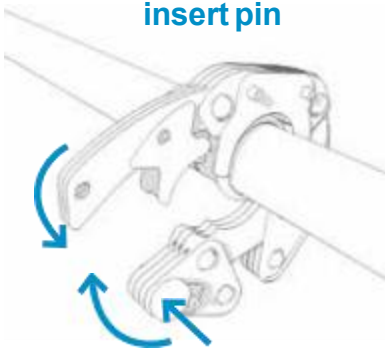

**4** Mount adapter

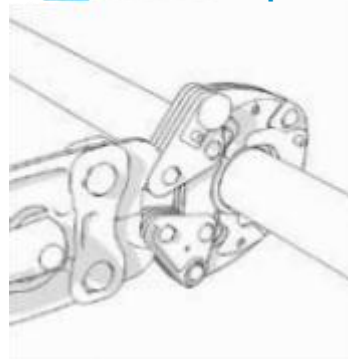

**5** Check

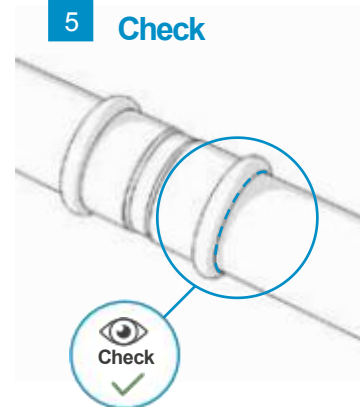

**6** Press



**7** Check

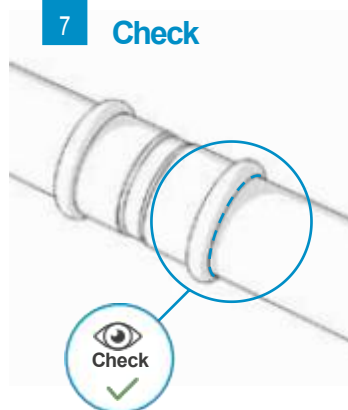

# Installation - Pressfitting

Diameters 76 - 108 mm / 2 3/4" - 4"

**0** Check O-ring for damage

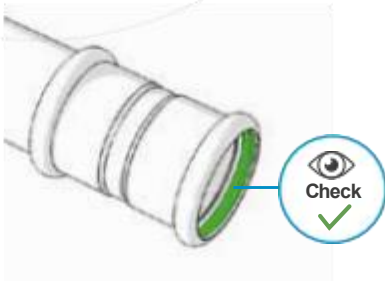

**1** Insert

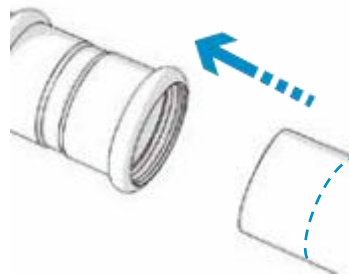

**2** Retract pin and open chain

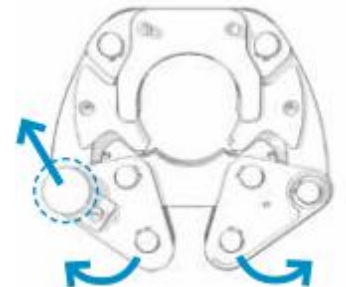

**3** Close chain and insert pin

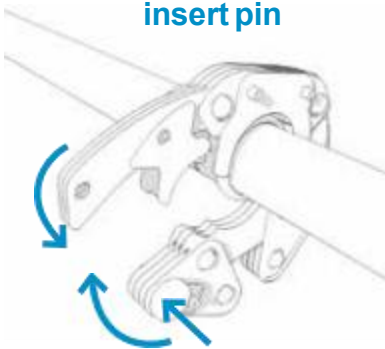

**4** Check

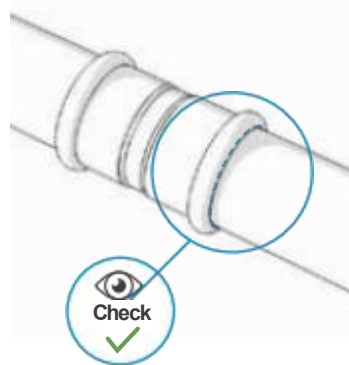

**5** Press

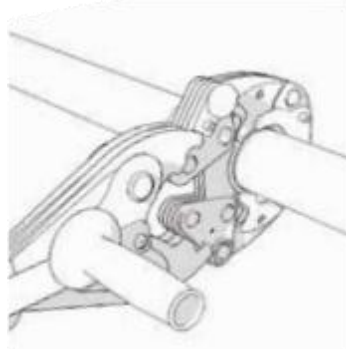

**6** Check

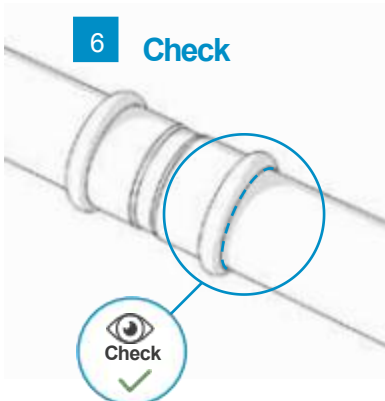

## Installation - Pressfitting

To carry out pressing correctly, there must be a minimum distance between the pipe and the building, and from pipe to pipe as shown in the tables below.

### Minimum distances and space requirements D15 - D35 / 1/2" - 1 1/4"

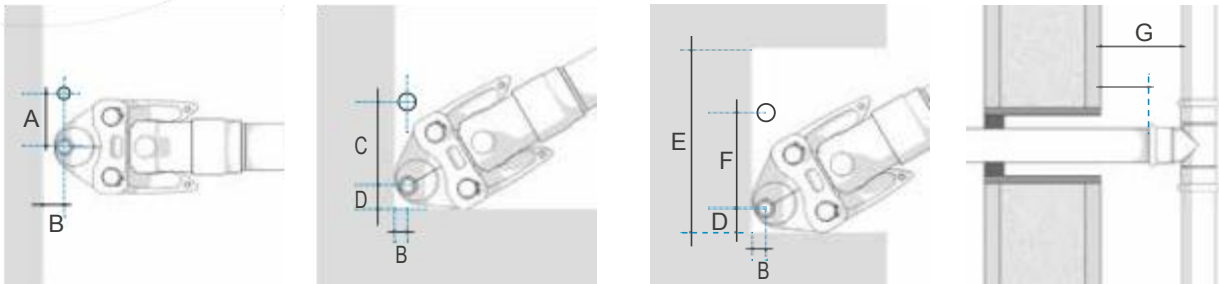

Diameter	A	B	C	D	E	F	G	H
D15 - 1/2"	56 mm 2 1/4"	30 mm 1 1/8"	75 mm 3"	35 mm 1 3/8"	155 mm 6 1/8"	95 mm 3 3/4"	60 mm 2 3/8"	40 mm 1 5/8"
D28 - 1"	82 mm 3 1/4"	40 mm 1 5/8"	90 mm 3 1/2"	45 mm 1 3/4"	180 mm 7 1/8"	90 mm 3 1/2"	63 mm 2 1/2"	40 mm 1 5/8"
D35 - 1 1/4"	85 mm 3 3/8"	40 mm 1 5/8"	90 mm 3 1/2"	45 mm 1 3/4"	180 mm 7 1/8"	90 mm 3 1/2"	66 mm 2 5/8"	40 mm 1 5/8"

### Minimum distances and space requirements D42 - D108 / 1 1/2" - 4"

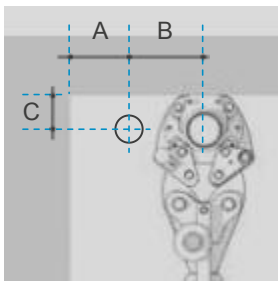

Diameter	A	B	C
D42 - 1 1/2"	150 mm 5 7/8"	150 mm 5 7/8"	110 mm 4 3/8"
D54 - 2"	150 mm 5 7/8"	150 mm 5 7/8"	110 mm 4 3/8"
D76 - 2 3/4"	170 mm 6 3/4"	210 mm 8 1/4"	170 mm 6 3/4"
D89 - 3 1/2"	190 mm 7 1/2"	260 mm 10 1/4"	190 mm 7 1/2"
D108 - 4"	200 mm 7 7/8"	320 mm 12 5/8"	280 mm 11"

**We deliver solutions of piping system**

**PIPRESS**

[WWW.PIPRESSTECH.COM](http://WWW.PIPRESSTECH.COM)

PIPRESS LIMITED

ZHEJIANG QILU TECHNOLOGY CO., LTD.